

Description

CRM60GK15EA are 3-phase Integrated Power Modules (IPM) designed for advanced appliance motor drive applications such as water pump, washing machine etc.

CRM60GK15EA Integrated 6 low-loss IGBTs and FRDs, 3-phase half bridge high voltage gate drivers in a familiar package. The modules are optimized for low EMI characteristics.

CRM60GK15EA internal integration of undervoltage, short circuit and other protection functions, providing excellent protection and a wide range of safe working area. The CRM60GK15EA designed with high insulation and easy thermal conductivity, especially suitable for compact installation.

Features

- 600V/15A three-phase inverter
- Works with 3.3V/5V MCU
- Built-in high voltage gate drive circuit
- Integrated under-voltage protection
- Integrated high accurate short-circuit current protection
- Integrated enable shut down function
- Integrated cross-conduction prevention logic
- Floating channel designed for bootstrap operation
- Isolation rating: 1500 Vrms/min

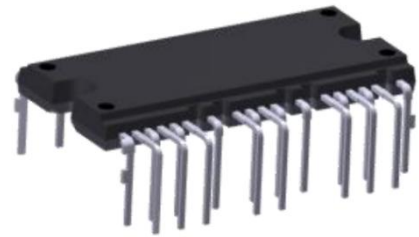

DIP-25A



Applications

- Washing machine
- Pumps

Package Marking and Ordering Information

Part #	Marking	Package	Packing	Quantity	Green
CRM60GK15EA	CRM60GK15EA	DIP-25A	Tube	825EA	ROHS/HF

Internal Electrical Schematic

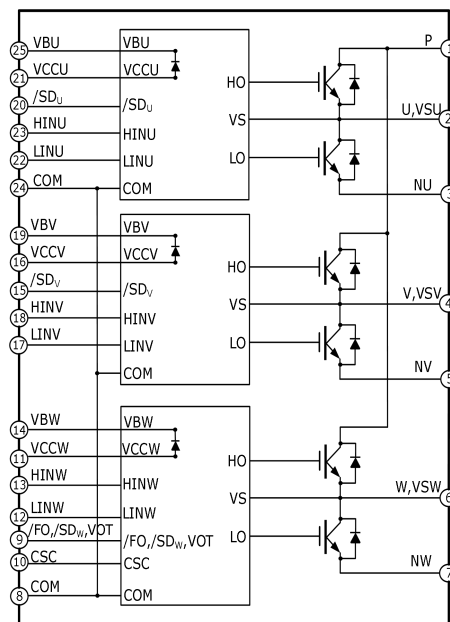

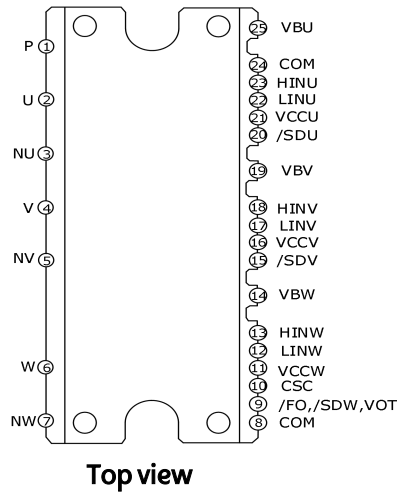
Module Pin-Out Description

Pin Number	Pin Name	Description
1	P	DC Bus Voltage Positive
2	U	Output - Phase U, High Side Floating Supply Offset U
3	NU	Phase U Low Side Emitter
4	V	Output - Phase V, High Side Floating Supply Offset V
5	NV	Phase V Low Side Emitter
6	W	Output - Phase W, High Side Floating Supply Offset W
7	NW	Phase W Low Side Emitter
8	COM	Logic Ground
9	/FO,/SD _w ,VOT	Fault output ,W phase shut down, Temperature Output
10	CSC	External capacitance, Over current shutdown input
11	VCCW	W phase IC supply voltage
12	LINW	Logic Input for Low Side Gate Driver - Phase W
13	HINW	Logic Input for High Side Gate Driver - Phase W
14	VBW	High Side Floating Supply Voltage W
15	/SD _v	V phase shut down
16	VCCV	V phase IC supply voltage
17	LINV	Logic Input for Low Side Gate Driver - Phase V
18	HINV	Logic Input for High Side Gate Driver - Phase V
19	VBV	High Side Floating Supply Voltage V
20	/SD _u	U phase shut down
21	VCCU	U phase IC supply voltage
22	LINU	Logic Input for Low Side Gate Driver - Phase U
23	HINU	Logic Input for High Side Gate Driver - Phase U
24	COM	Logic Ground
25	VBU	High Side Floating Supply Voltage U

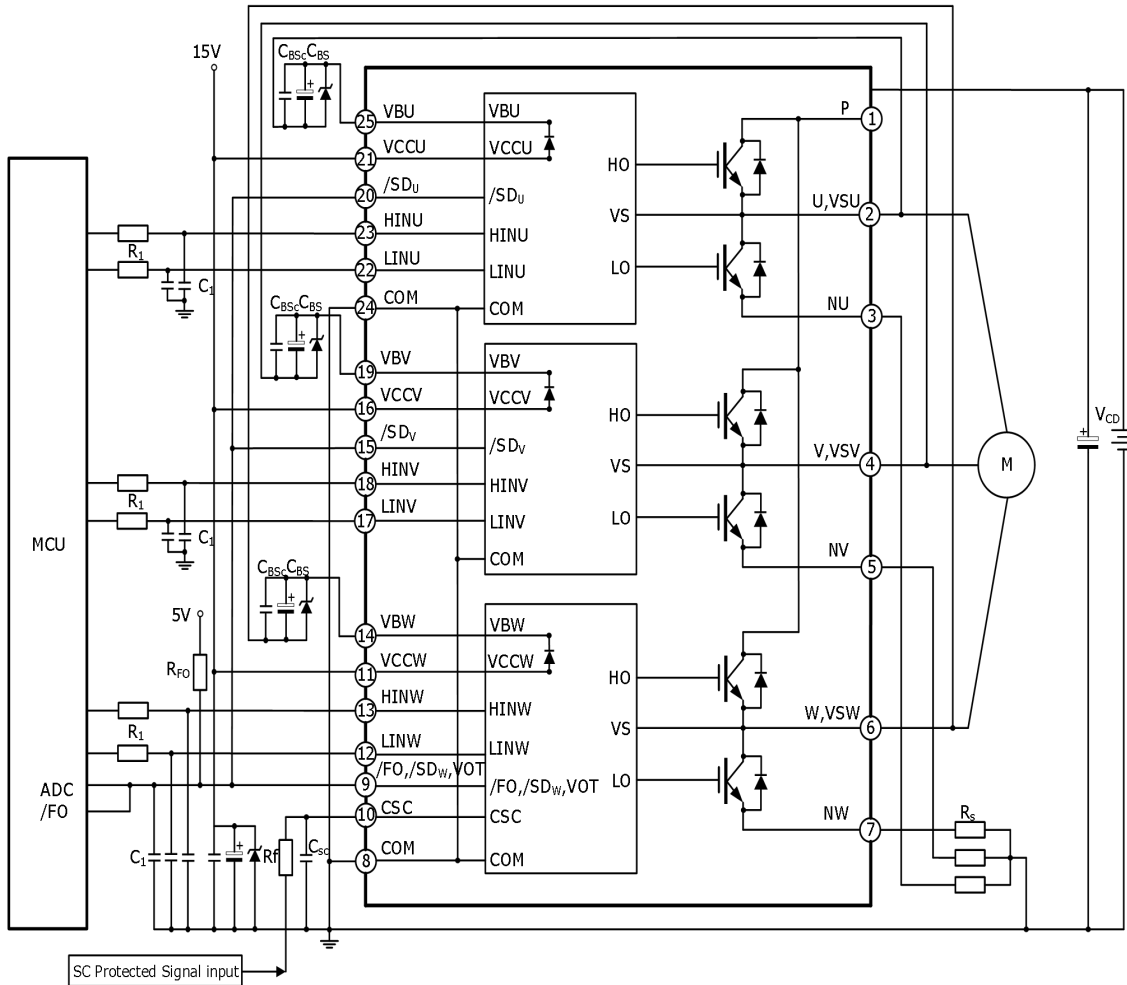
Application Circuit

Remark:

1. To prevent malfunction, the wiring of each input should be as short as possible.
2. Input drive is High-Active type. There is a $9.6k\ \Omega$ (typ.) pull-down resistor integrated in the IC input circuit. And adding RC filter circuit to the input will prevent the surge noise caused by incorrect input.
3. To prevent surge damage, it is recommended to add a high-frequency non-inductive flat capacitor ($0.1\mu F$ to $0.22\mu F$) between P and N. The cable connection of the capacitor should be as short as possible.
4. The line between the current detection resistor and the IPM should be as short as possible, otherwise the large surge voltage generated by the connecting inductor may cause damage.
5. All capacitors should be mounted as close to the terminals of the IPM as possible.
6. /FO output is open drain type. It should be pulled up to the positive side of 5V power supply by a resistor of about $6.8k\ \Omega$.
7. The time constant R_f and C_{sc} of the protection circuit should be selected in the range of $1.5\text{-}2.0\ \mu s$.

Package Outline
DIP-25A

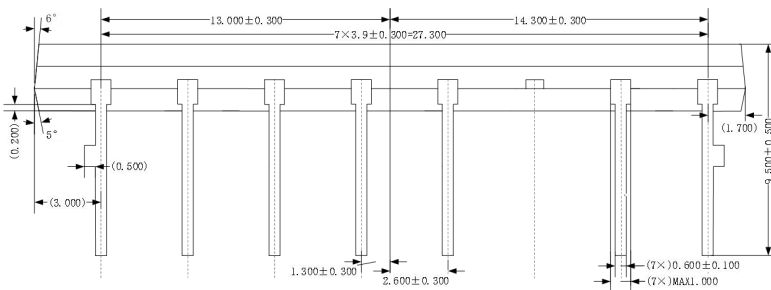
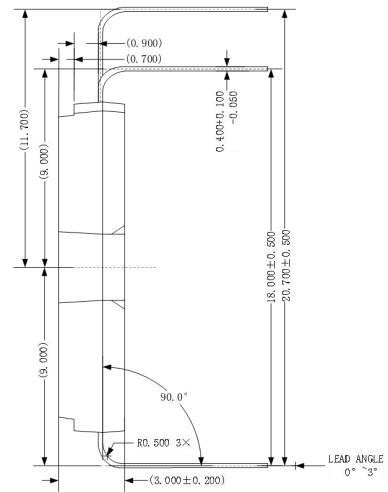
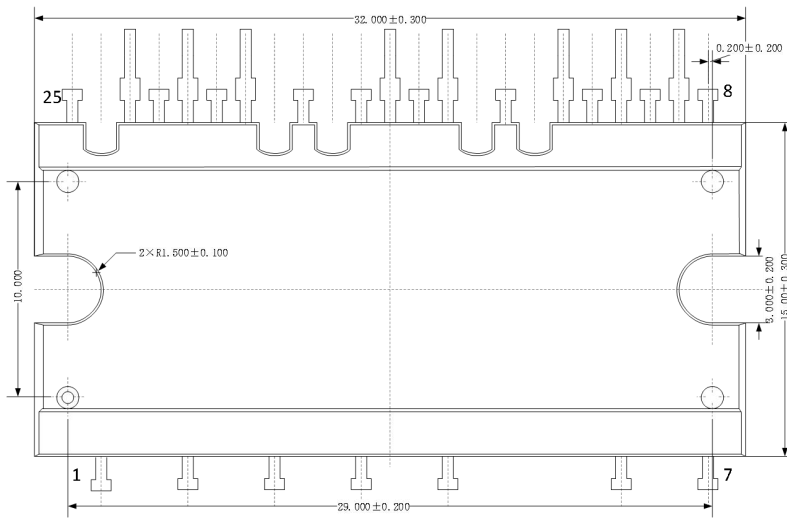
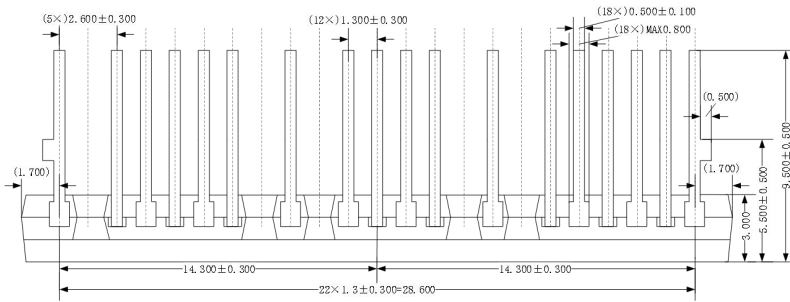
UNIT:mm



Disclaimer

Unless otherwise specified in the datasheet, the product is designed and qualified as a standard commercial product and is not intended for use in applications that require extraordinary levels of quality and reliability, such as automotive, aviation/aerospace and life-support devices or systems.

Any and all semiconductor products have certain probability to fail or malfunction, which may result in personal injury, death or property damage. Customer are solely responsible for providing adequate safe measures when design their systems.

CRM(CQ) reserves the right to improve product design, function and reliability without notice.